



Front Operated Toilet Service Unit – TSU-F with vacuum evacuation

The TSU-F is built on a specially designed low profile chassis and equipped with an elevating platform to facilitate handling of all aircraft types. The TSU-F is customized to meet the specific requirements and preferences of individual customers, and constructed exclusively from first class components. All major components of vacuum, fluid, hydraulic and electrical systems are standard and thoroughly tested.

The **elevating platform** is placed beside the driver's cabin and is easy to enter at ground level. The TSU-F drives forwards towards the aircraft. The platform is equipped with a user friendly **control panel** that gives the operator a clear view of all the necessary functions. The waste hose and the flush/filling hose are easy to access from the ground and elevate with the platform.

Top-hinged engine hood at the rear of the vehicle provides excellent accessibility to the **machine room**. Parts and cables are marked according to the diagrams.



The stainless steel **tanks** are placed in the center of the vehicle and are accessible through manholes. The waste tank is actively cleaned when dumping through its hydraulically operated valve.

The TSU-F is available with a **batch mix system**, that mixes disinfectant and water to a user specified concentration, as it is filled into the aircraft.

Fluid system and tank section are fully insulated for **winter protection**, and optional anti-freeze heater systems are available. To protect the couplings from freezing, a coupling heater can be placed on the platform. The optional **steam generator** removes ice from the aircraft panel and piping.



MAJOR ADVANTAGES

- Powerful vacuum evacuation system for ultimate efficiency and safety
- Reduced time and cost per operation
- Reduced manpower consumption
- Hygienic operator's environment
- Large vacuum tank capacity
- Reduced demand for flush
- Prevents blockage, leakage and formation of ice at aircraft valves
- Elevating operator's platform for serving all types of aircraft
- Unsurpassed unit life time and low maintenance costs

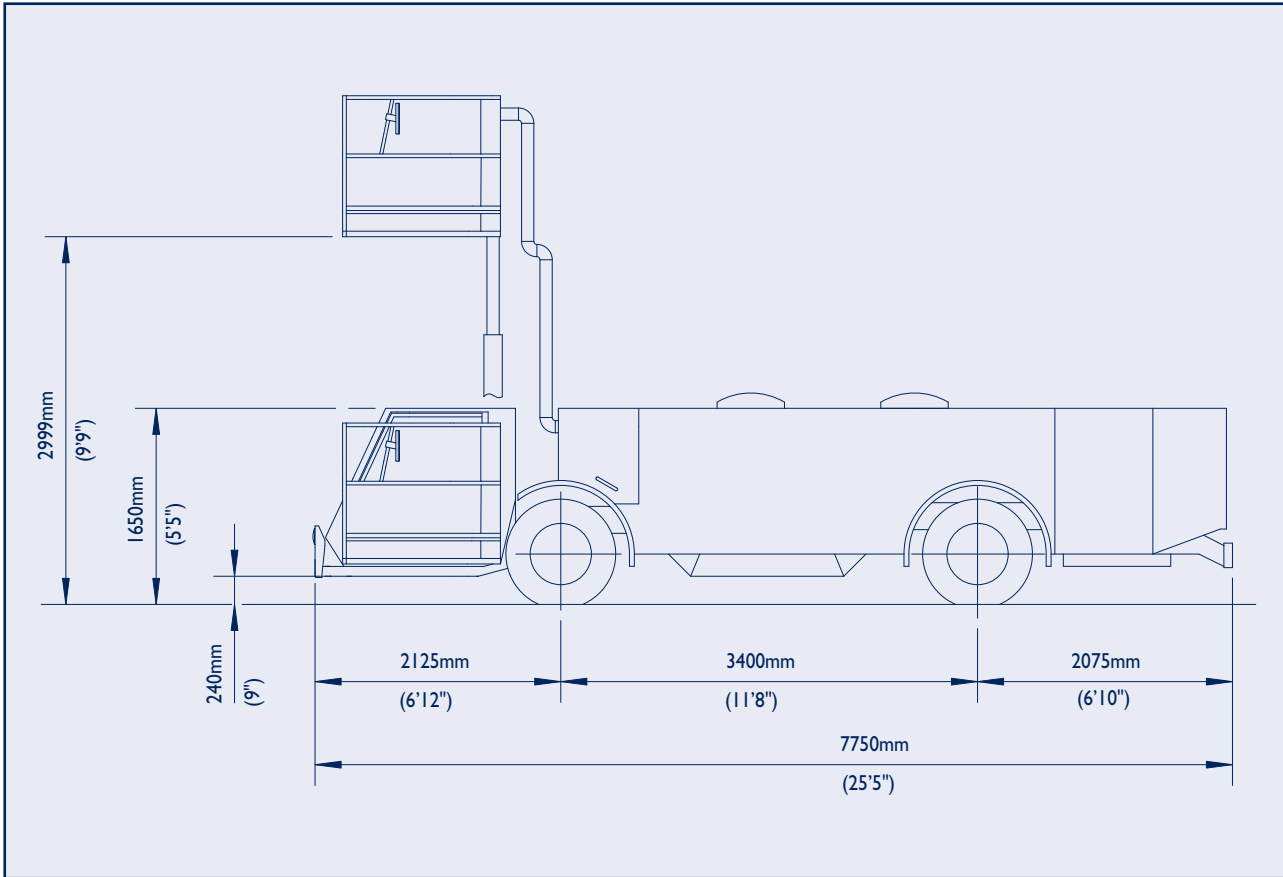

Specifications	Driver's Cabin Panel
Overall height, lowered: 1.65 m (5'5")	Unit on/off switch
Cab elevation: 0.75 m (2'6")	Control light for engaged PTO
Turning radius: 7.8 m (25'7")	LED level indication for all tanks
Max. working height: 4.80 m (15'9")	Low level shut down
Max. vacuum: 0.25 bar (3.5 psi) differential pressure (reached within 8-10 sec)	Light switches
Max. flushing flow: 100 l/min. @ 3.5 bar (26 gal US/min.)	Emergency stop switch
Max. flushing pressure: 3.5 bar (50 psi)	
Waste tank capacity: 2500 liters (660 gal US)	Platform Control Panel
Flush tank capacity: 1700 liters (450 gal US)	Platform up/down
Tank section insulated for winter operations	Water/disinfectant on/off
Return suction in flush line	Vacuum pump on/off
Optional mixing system for disinfectant fluid	Pre-selection of fluid
Optional heating systems	Vacuum valve open/close
Optional steam generator for de-icing of service point	Emergency pump
PLC onboard	Emergency stop
	Fluid counter with flow meter