



Small Water Service Unit - SWS

Small Water Service Unit - SWS has been developed especially for use at airports servicing commuter traffic, for handlers with relatively low handling frequencies, or as a back-up unit for the larger Water Service Units.

Features:

SWS can optionally be mounted on a gasoline-, diesel-, or electrically powered carriage, or optionally on a towable carriage. The aggregate is thus prepared to be powered either electrically or hydraulically from the carriage.

Tank:

The basic unit consists of one tank with a 500 or 1000 liter capacity. The tank is equipped with a 400mm manhole providing easy access for cleaning of the tank. A mechanical fluid counter allows for the precise required delivery of water into A/C tank.

Heating (Winter protection):

The unit can optionally be insulated and equipped with a heating device. This option is highly recommended in low-temperature geographical areas.

Our product line of Water Service Units:

- WS** Water Service Unit
- WSU-F** Front-operated Water Service Unit
- MWS** Medium Water Service Unit
- SWS** Small Water Service Unit

MAJOR ADVANTAGES

- Excellent for handling of A/C with low-positioned water filling systems
- A small, easy and maneuverable unit
- Efficient and fast handling
- Optionally mounted on a self-propelled or towable carriage
- Reliable construction
- Highly competitive price

SWS SPECIFICATIONS

Dimensions: On Sprinter Chassis Overall length Overall width	Tank capacity: 500 or 1000 liter	Max. water flow: 90 l/min	Chassis: Eg. Sprinter 211 CDI or Towable trailer
5,3 m 1,9 m			

We reserve the right to improve or change models and specifications without notice.

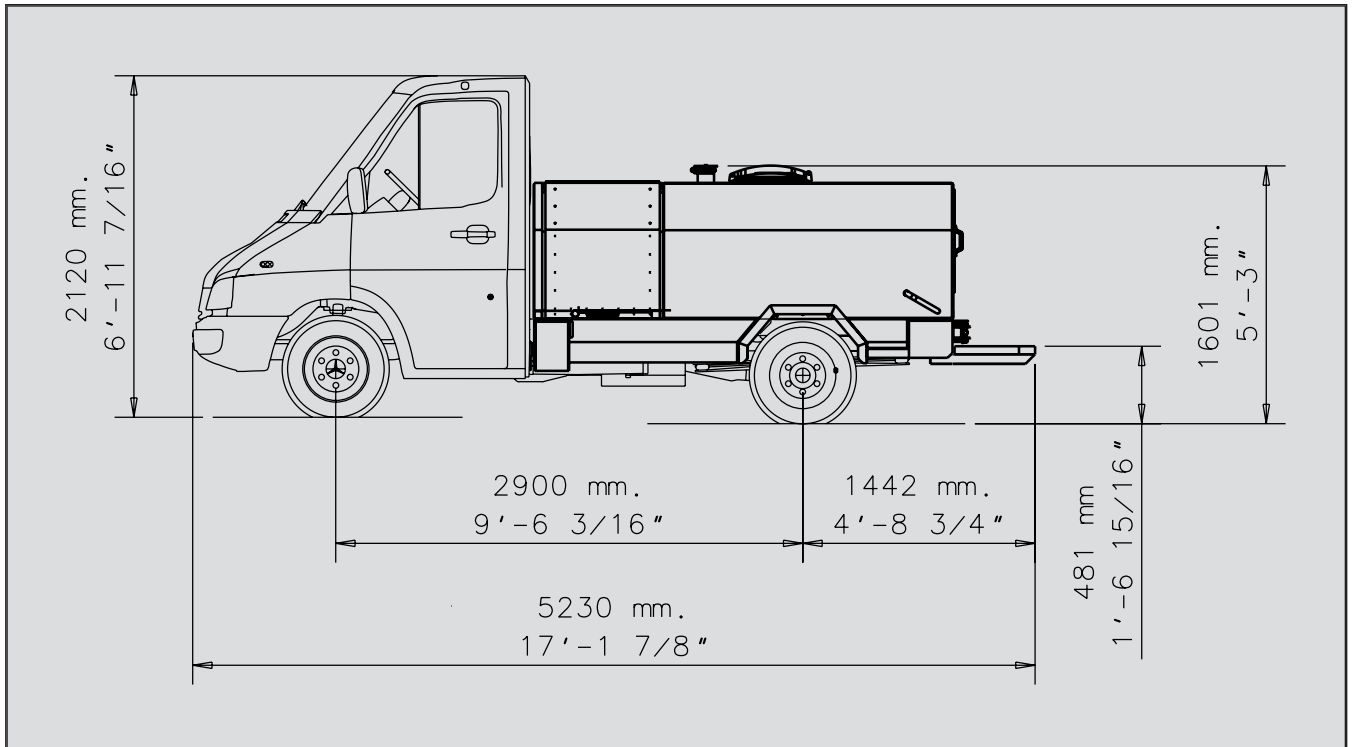

Specifications

Max water flow: 90 l/min. @3,5 bar (50 psi)

Water tank capacity 500 or 1000 liter

Tank section optionally insulated for winter operations

Return suction in water line

Optional heating systems

Optional steam generator for de-icing of service point

Standard truck chassis (Mercedes Sprinter 211 CDI, Isuzu NPR or similar)