



MAJOR ADVANTAGES

- Based on proven technology
- Highly reliable in operation
- First-class workmanship
- Chassis selected by customer
- Safe manoeuvring around the aircraft

Aircraft Washer

Based on the highly successful Elephant[®] My de-icer, of which Vestergaard has delivered over 400 units as per early 2011, the Vestergaard Elephant[®] My Aircraft Washer is available for customers with a specific need for aircraft washing. Using the components and systems from de-icing systems that have already proven themselves over the years,

the Elephant[®] Aircraft Washer is a unique, purpose-built truck, providing customers with reliable and efficient aircraft washing capability. The unit provides for fluid flows at 240 litres/min, a designated tank for detergent, and customers may select chassis make of their preference (f.ex. Mercedes, Volvo, MAN or others).

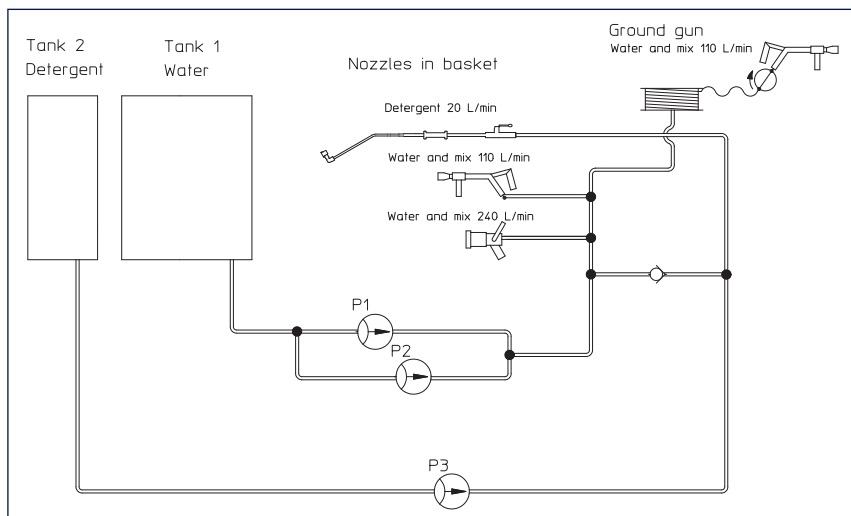

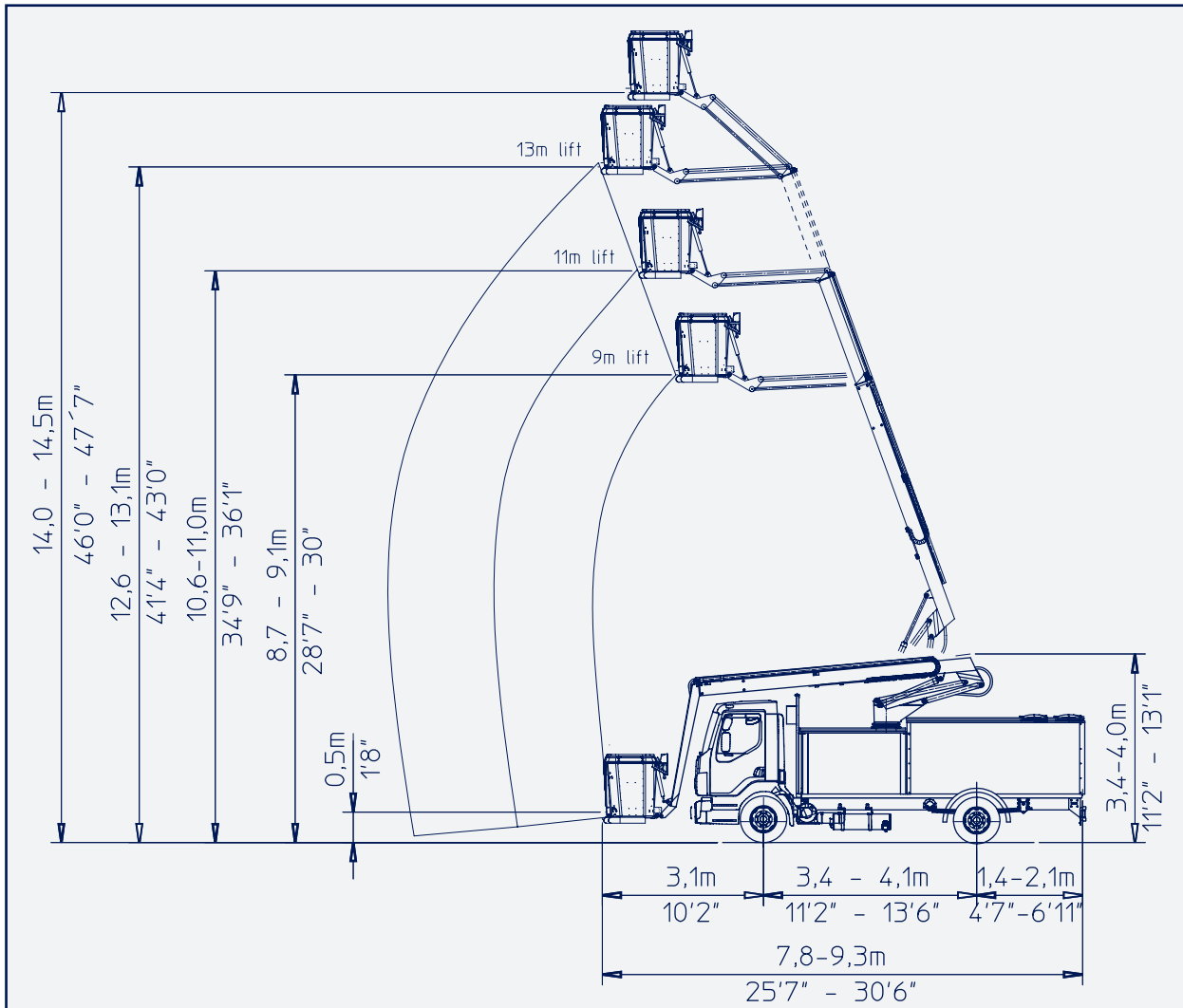

Specifications

Maximum lifting height:	see above	Total tank capacity:	4000, 5600 or 7600 litres (1060, 1480 or 2010 gal US)
Overall height (typically):	3.8 m (12'6")	Two or three tank configuration available.	
Overall width:	2.6 m (8'7")	Weight (empty tanks):	8.5 - 12.5 Tons (metric)
Overall length (typically):	9.0 m (29'6")	Hot water option available.	
		One-man (drive from basket) option available.	
		Fluid selections:	100% Water 10% Detergent 20% Detergent 100% Detergent

Efficient corrosion protection: lifting basket in aluminum, coating og hollow frame members internally, sandblasting and metallizing of exposed areas before painting with primer, undercoat and top enamel.